

Wiring Diagram List

DIAGRAM	LOCATION
Battery Power Distribution	Figure B-3
Ignition and Accessory Power Distribution: Except FXS and FLS	Figure B-4
Ignition and Accessory Power Distribution: FXS	Figure B-5
Ignition and Accessory Power Distribution: FLS	Figure B-6
Sensor Grounds	Figure B-7
Ground Circuit: Except FXS and FLS	Figure B-8
Ground Circuit: FXS and FLS	Figure B-9
Front Lighting and Hand Controls: 2013 Softail	Figure B-10
Main Harness 1 of 2: 2013 Softail (Except FXS and FLS)	Figure B-11
Main Harness 2 of 2: 2013 Softail (Except FXS and FLS)	Figure B-12
Main Harness 1 of 3: 2013 Softail (FXS)	Figure B-13
Main Harness 2 of 3: 2013 Softail (FLS)	Figure B-14
Main Harness 3 of 3: 2013 Softail (FXS and FLS)	Figure B-15
Rear Lighting: 2013 Softail	Figure B-16



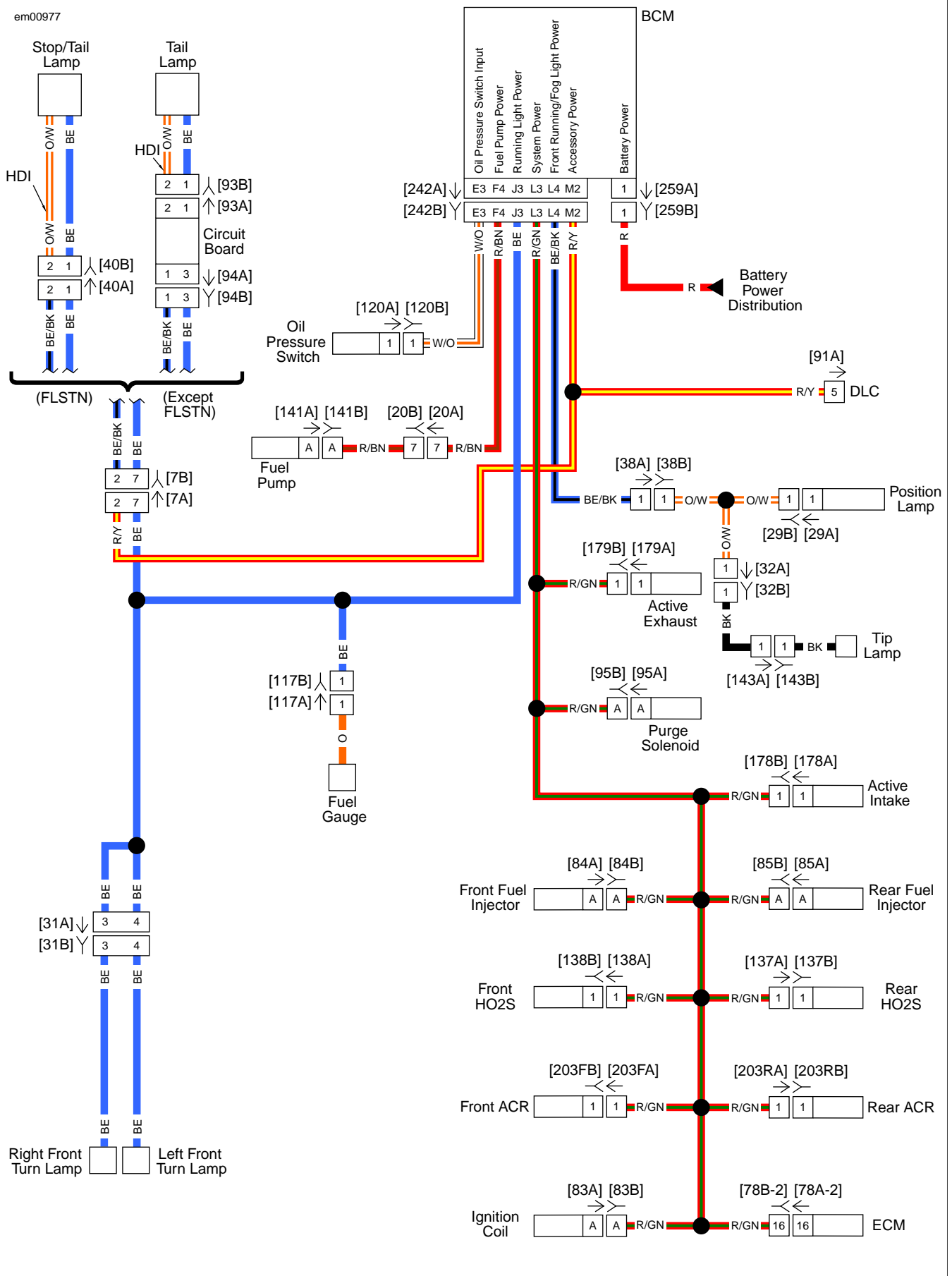

Figure B-4. Ignition and Accessory Power Distribution: Except FXS and FLS

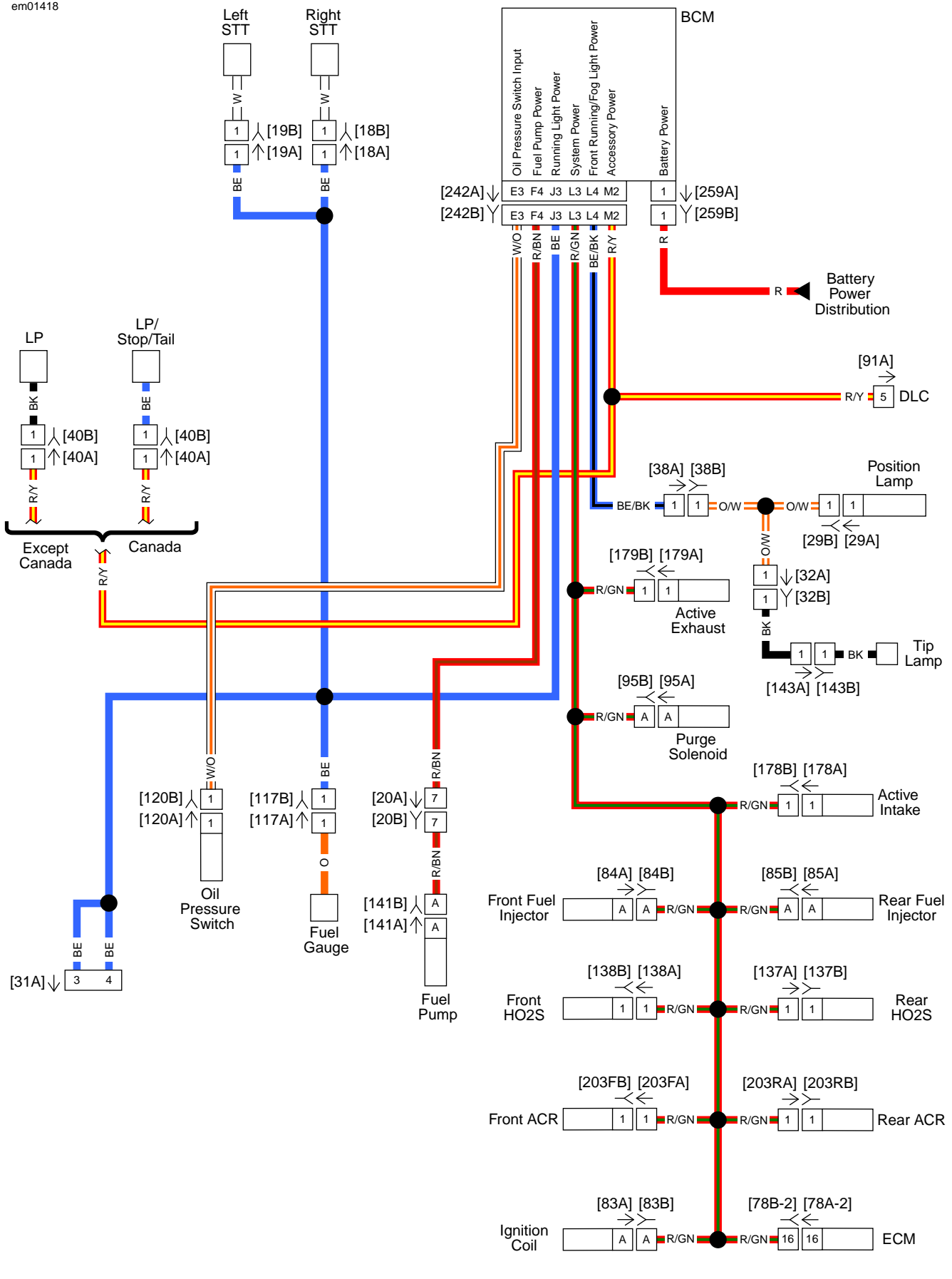

Figure B-6. Ignition and Accessory Power Distribution: FLS

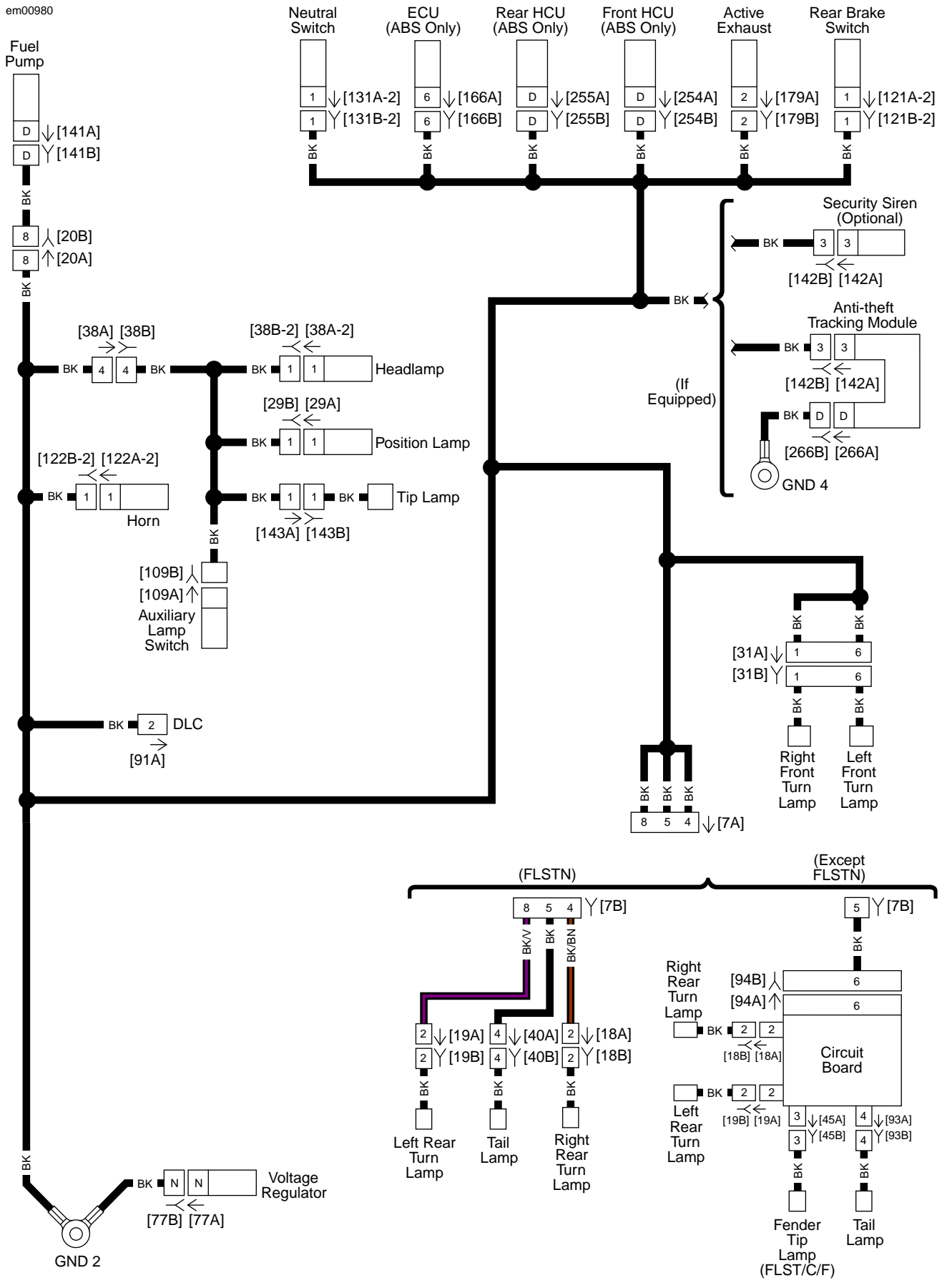

Figure B-8. Ground Circuit: Except FXS and FLS

Battery Power

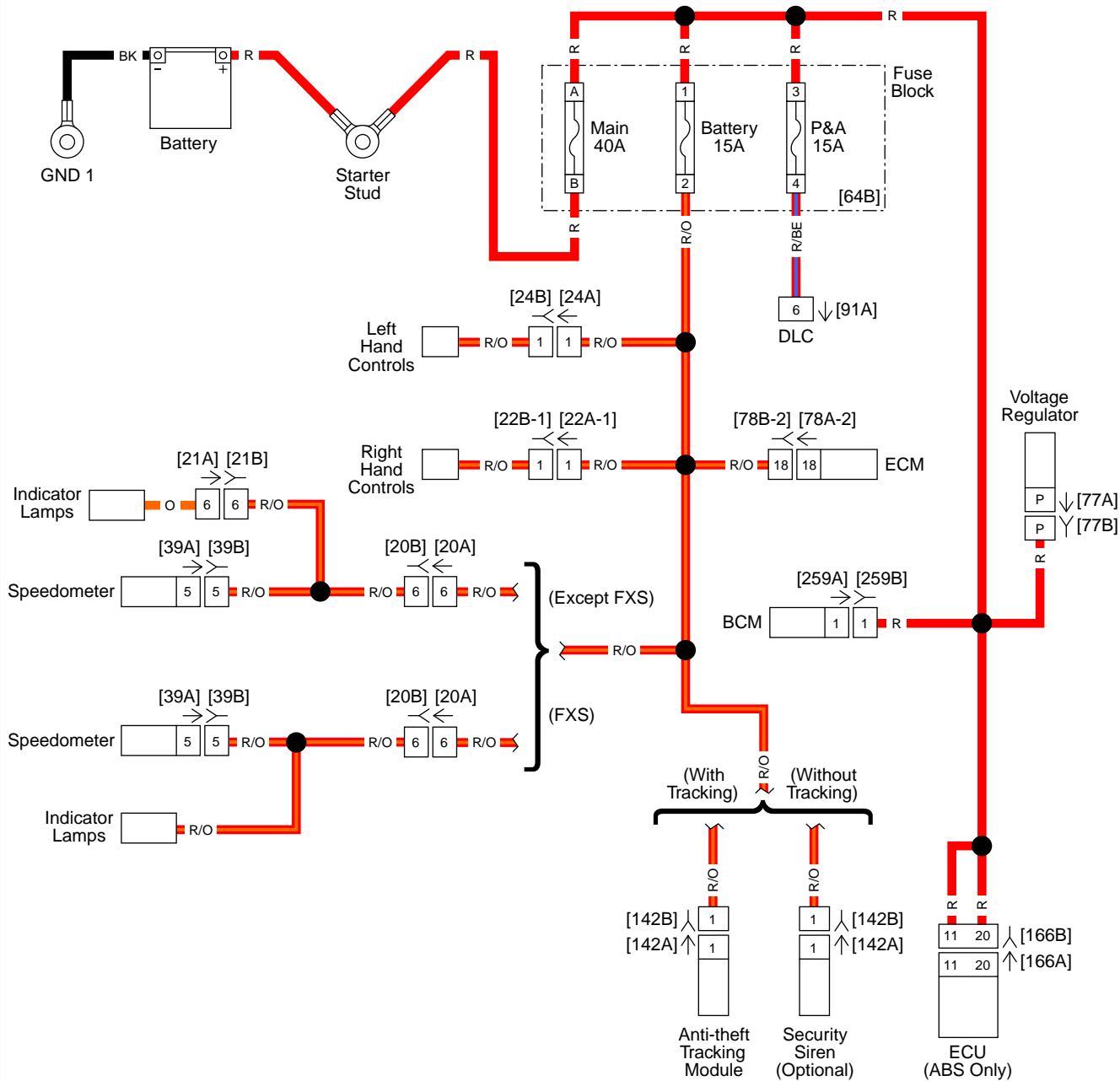

Figure B-3. Battery Power Distribution

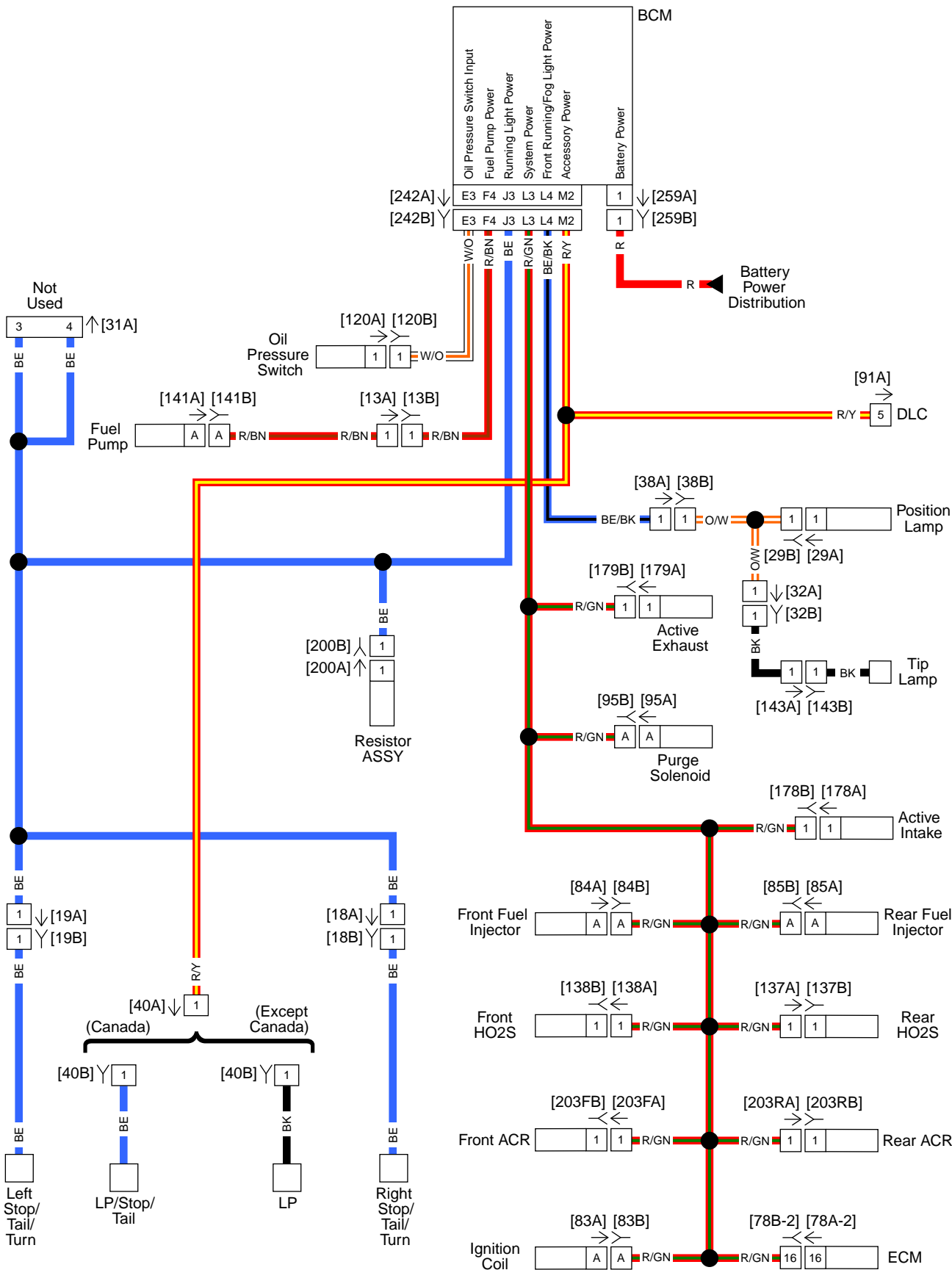

Figure B-5. Ignition and Accessory Power Distribution: FXS

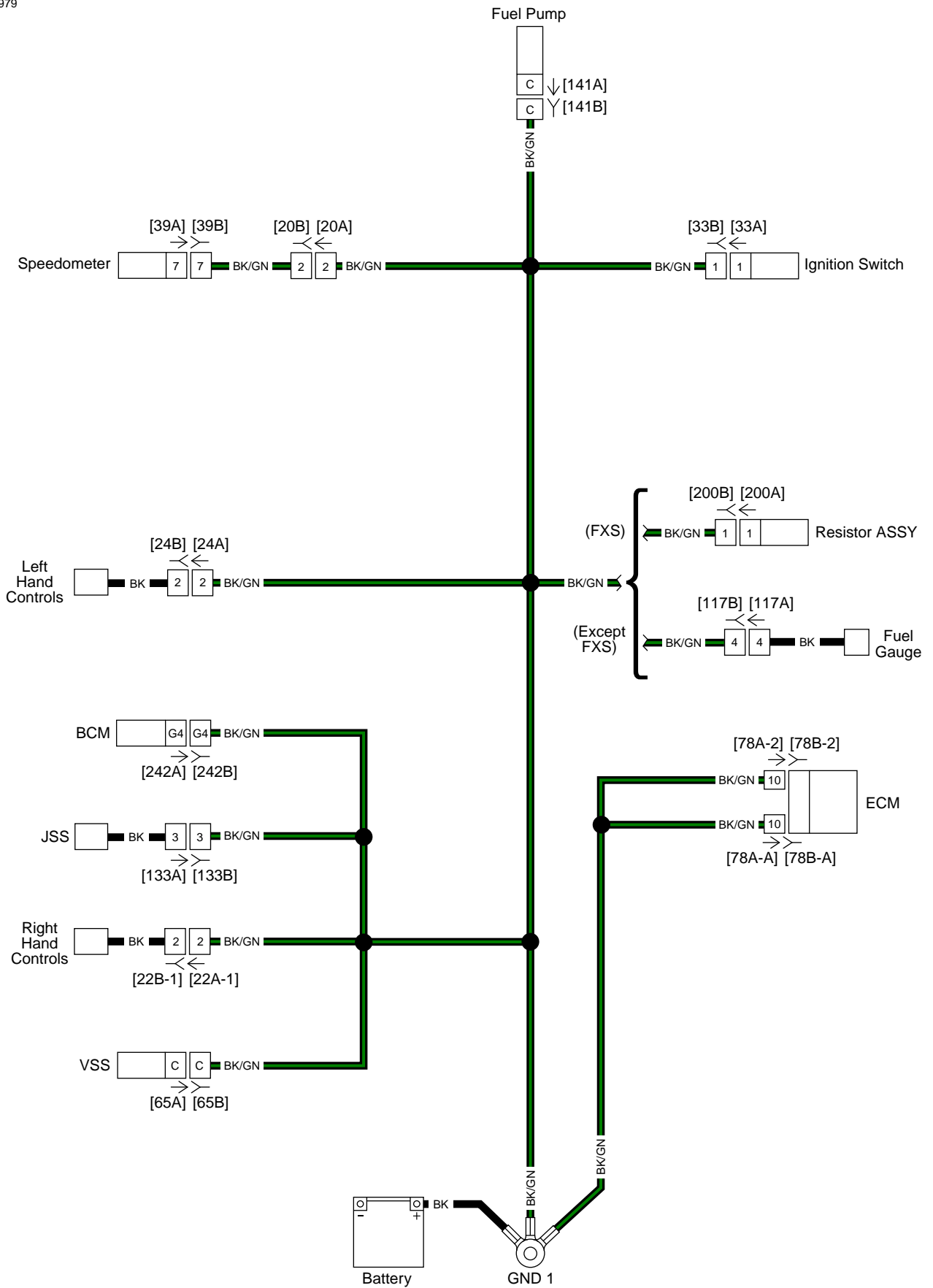

Figure B-7. Sensor Grounds

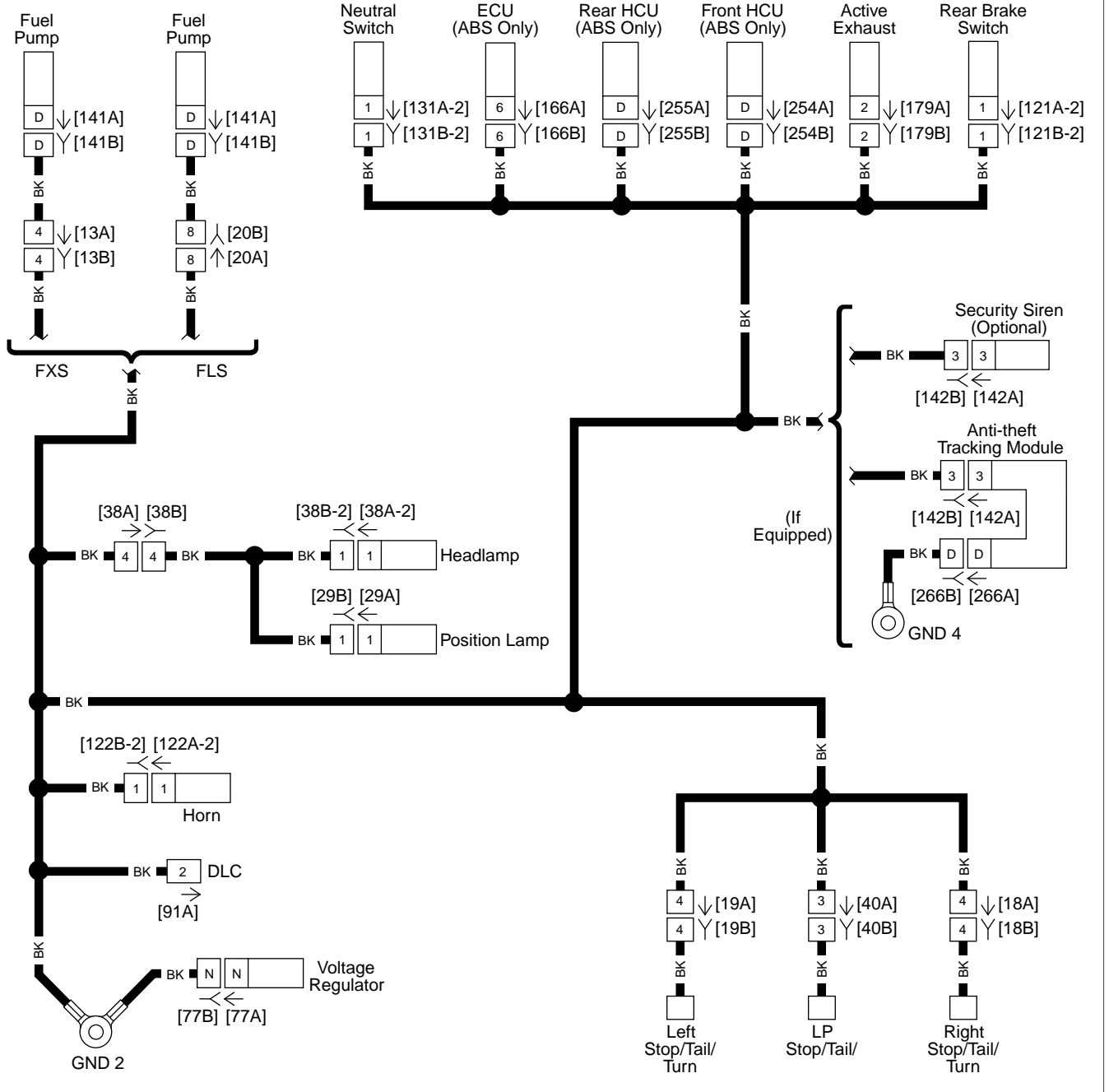

Figure B-9. Ground Circuit: FXS and FLS

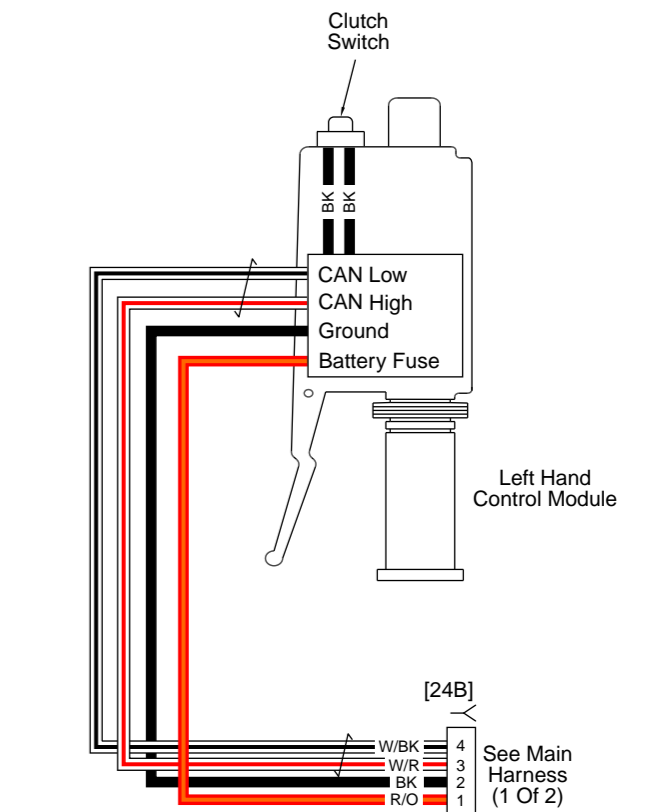
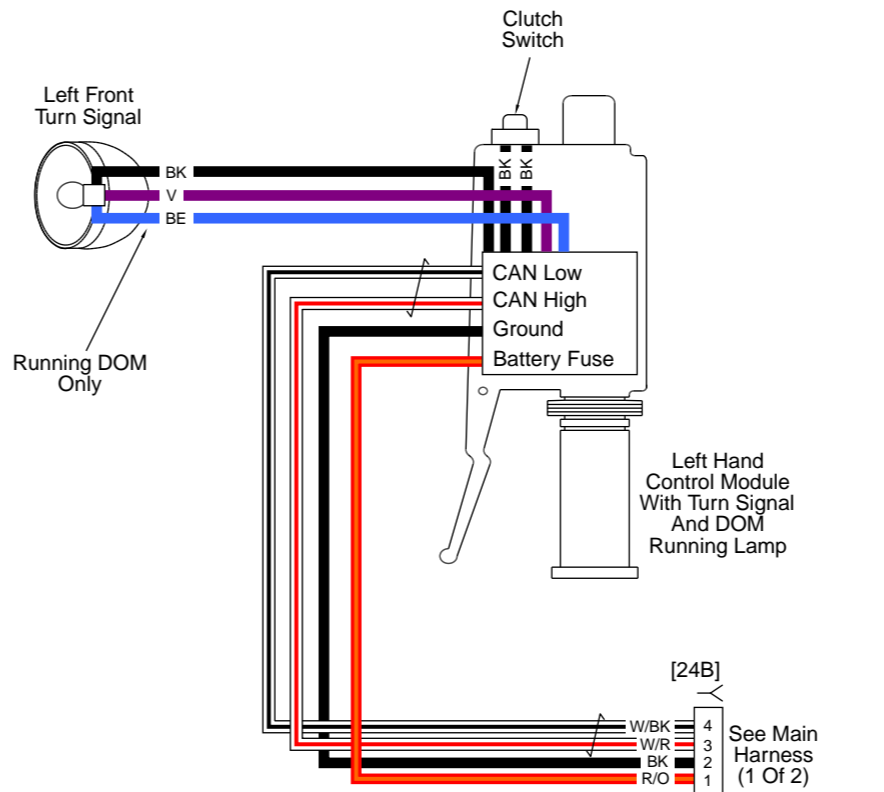
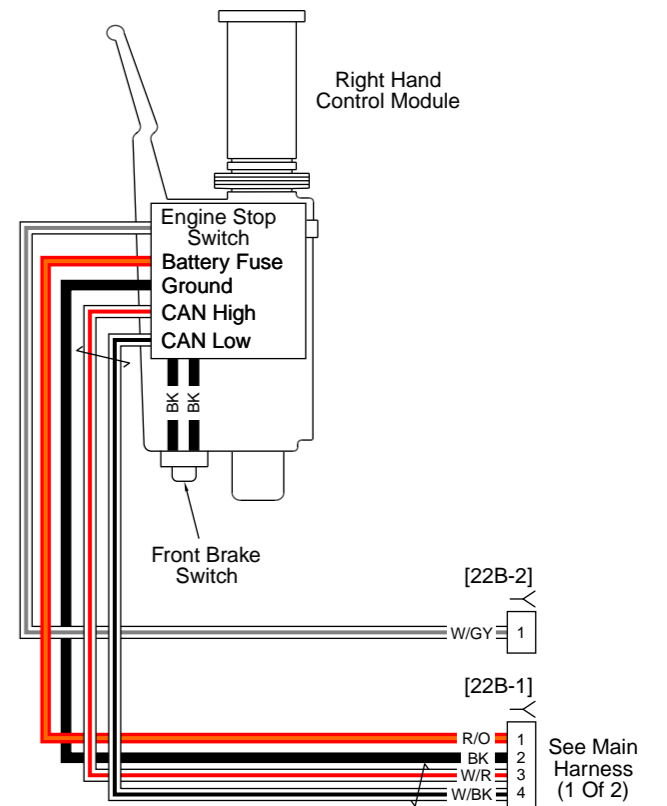
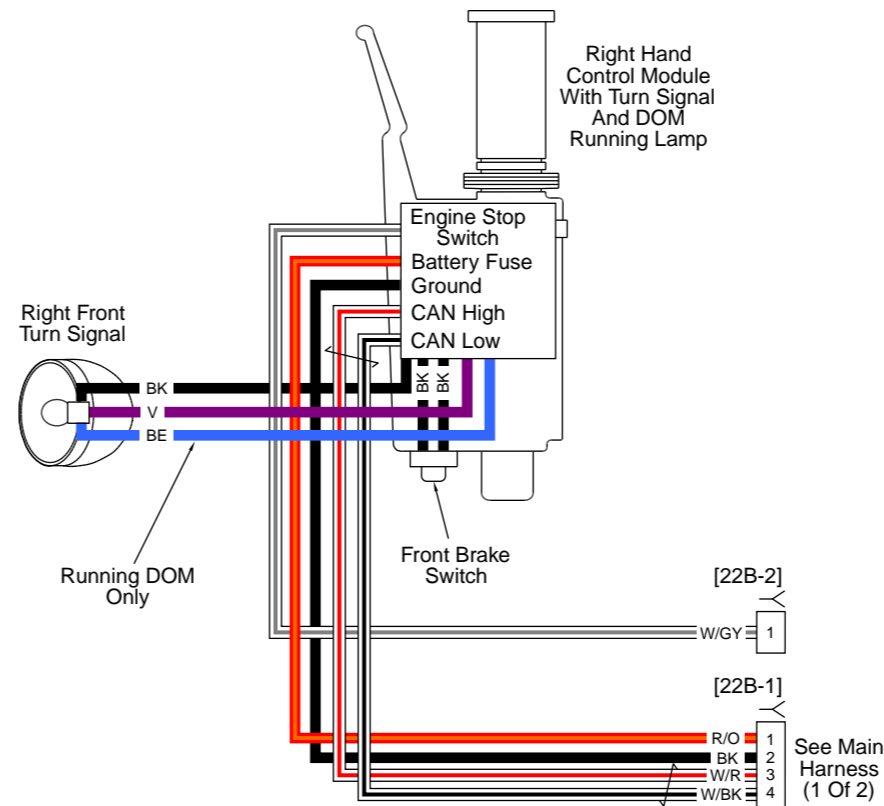
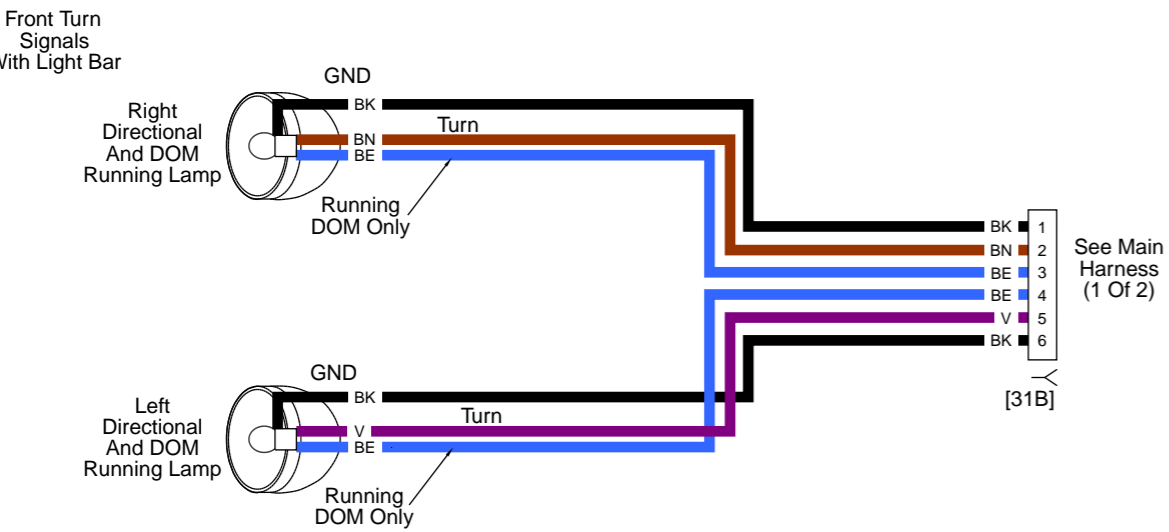
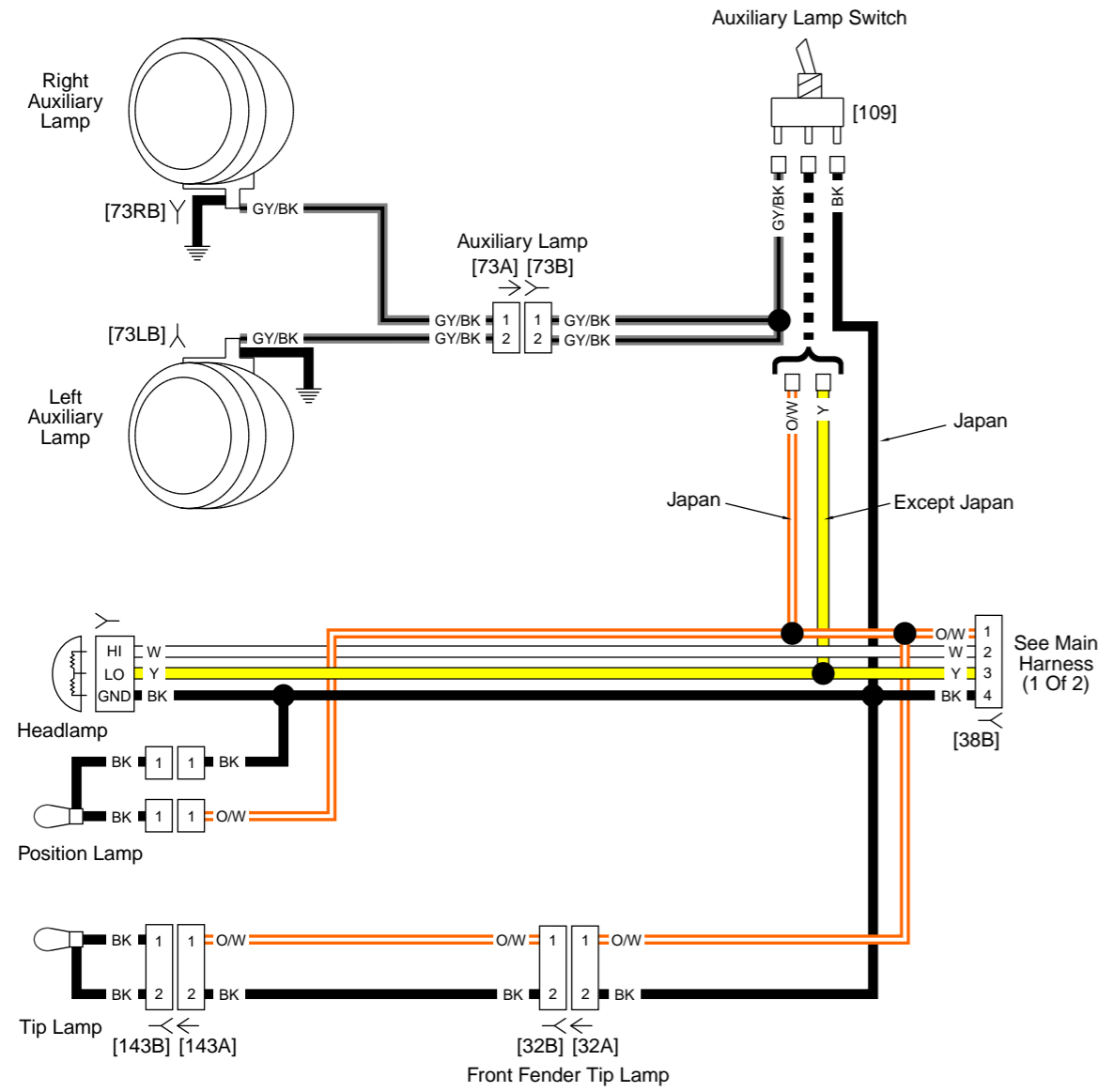

Figure B-10. Front Lighting and Hand Controls: 2013 Softail

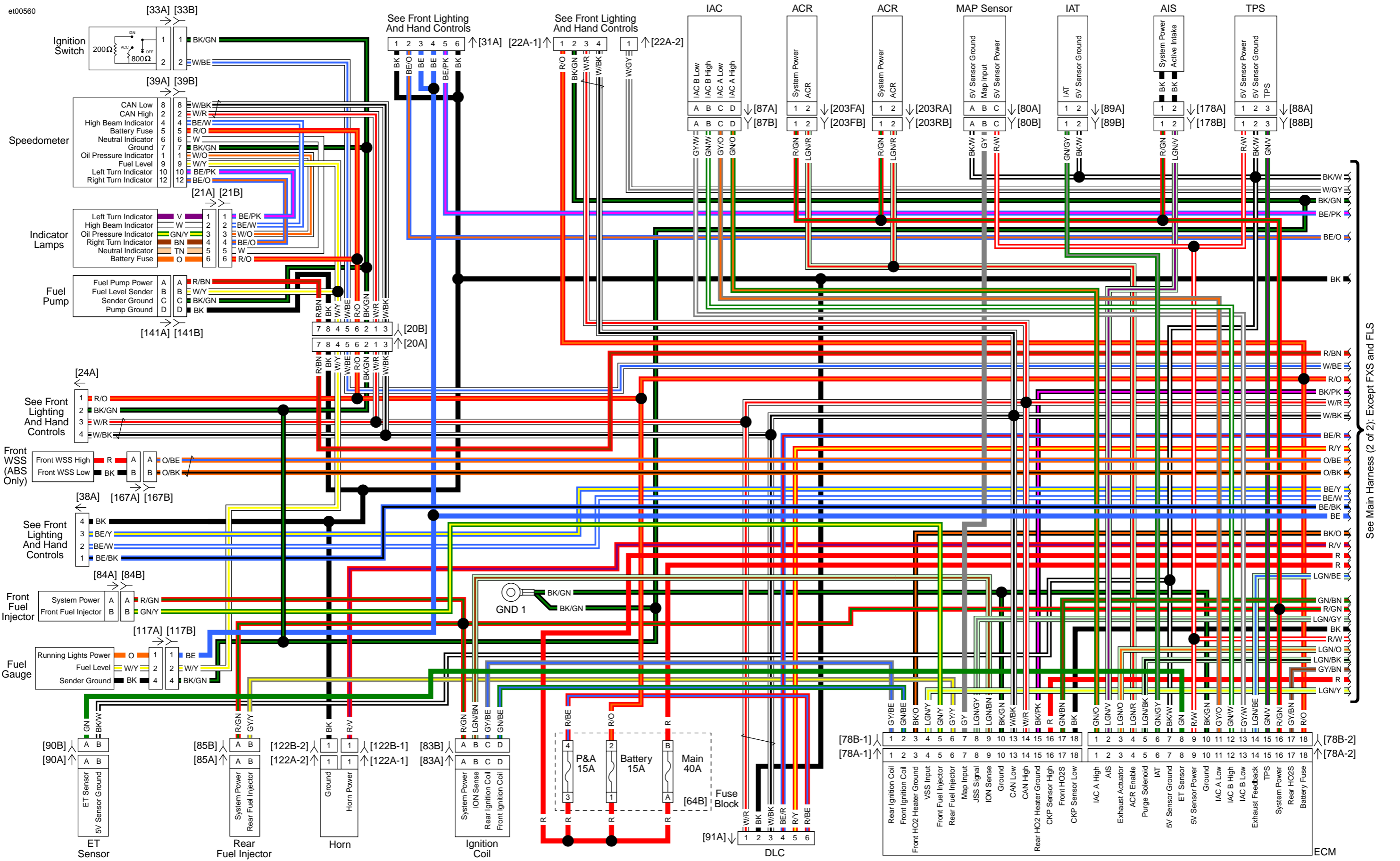

Figure B-11. Main Harness 1 of 2: 2013 Softail (Except FXS and FLS)

See Main Harness (1 of 2), Except FXS and FLS

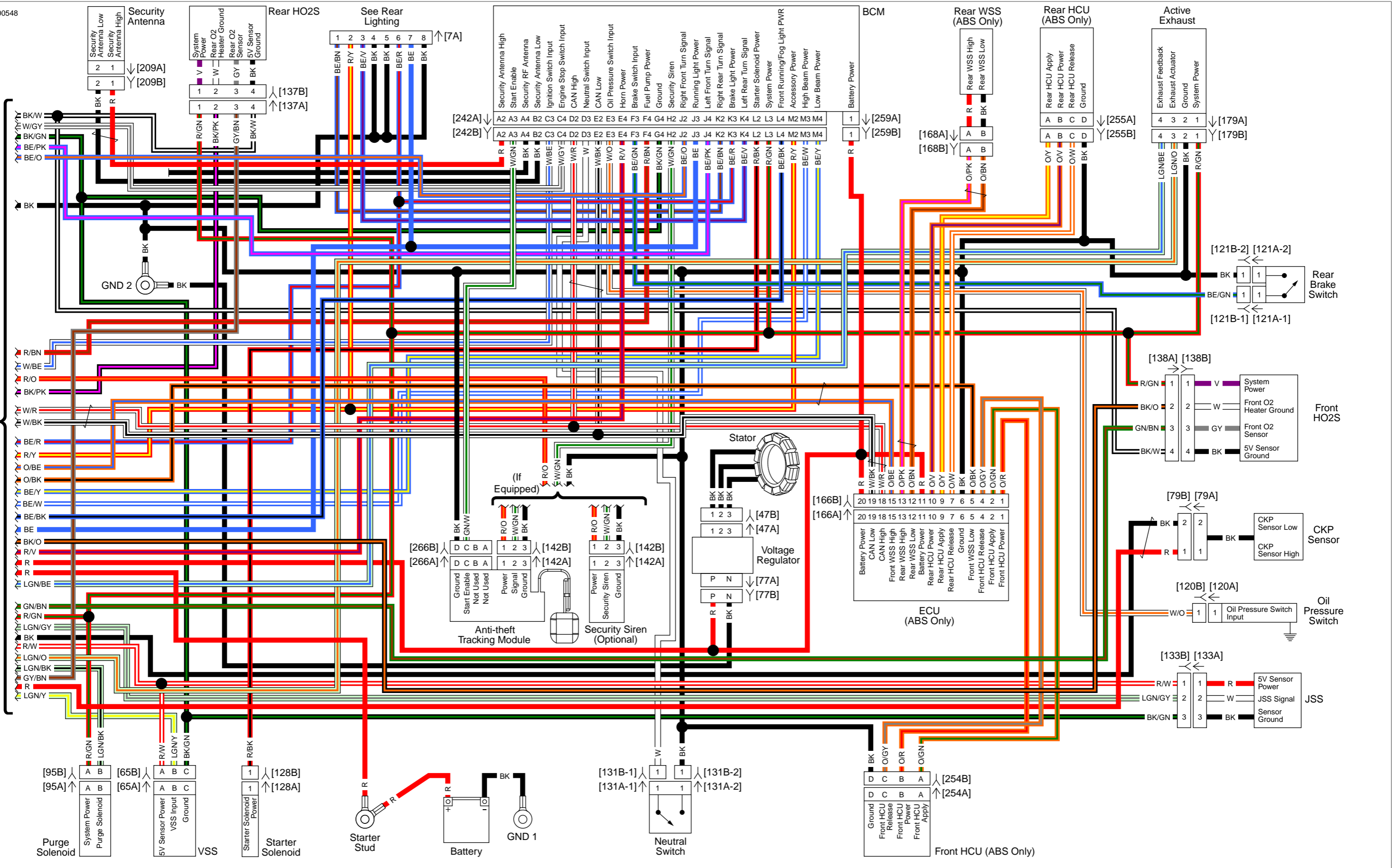
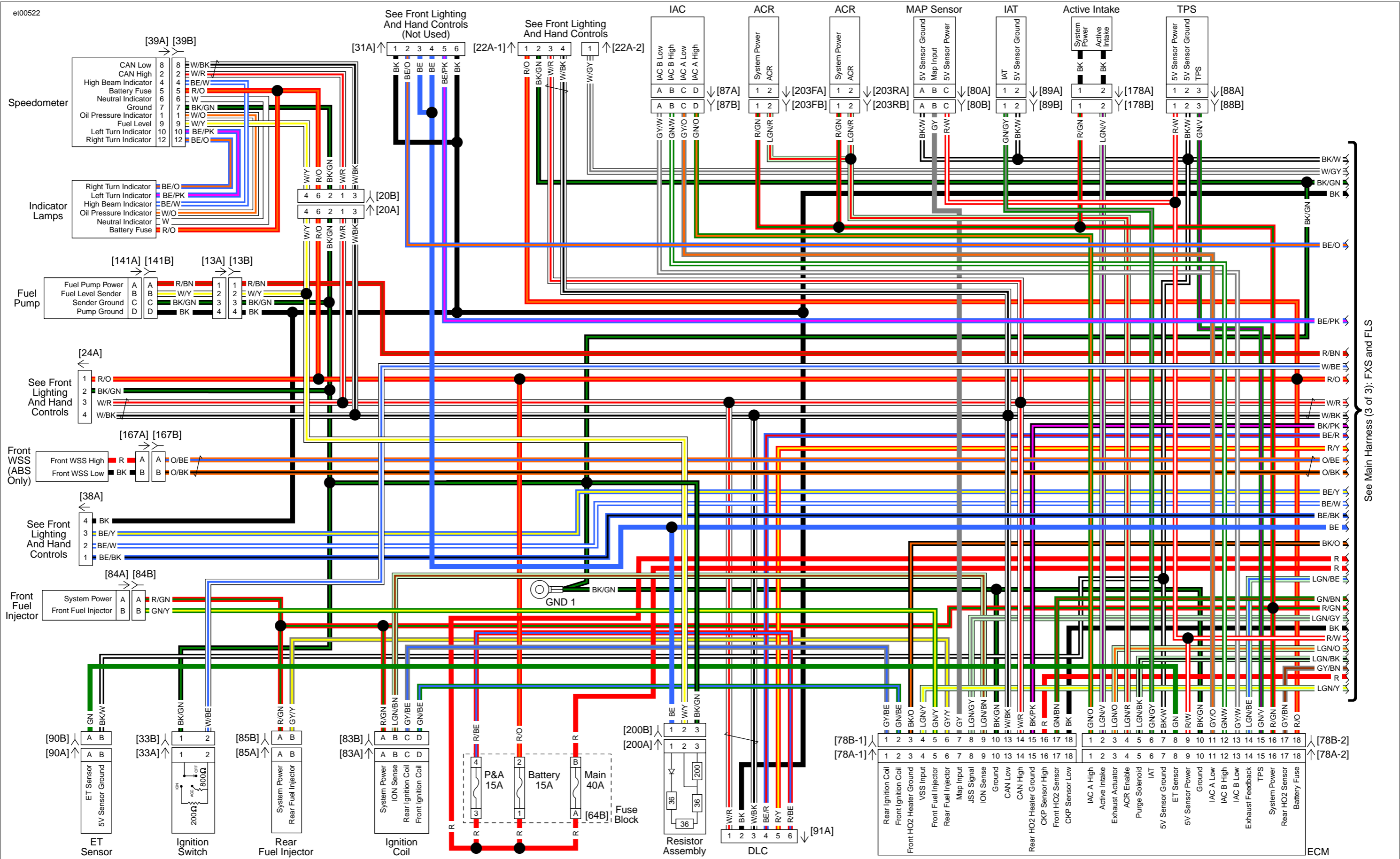

Figure B-12. Main Harness 2 of 2: 2013 Softail (Except FXS and FLS)



See Main Harness (3 of 3): FXS and FLS

Figure B-13. Main Harness 1 of 3: 2013 Softail (FXS)

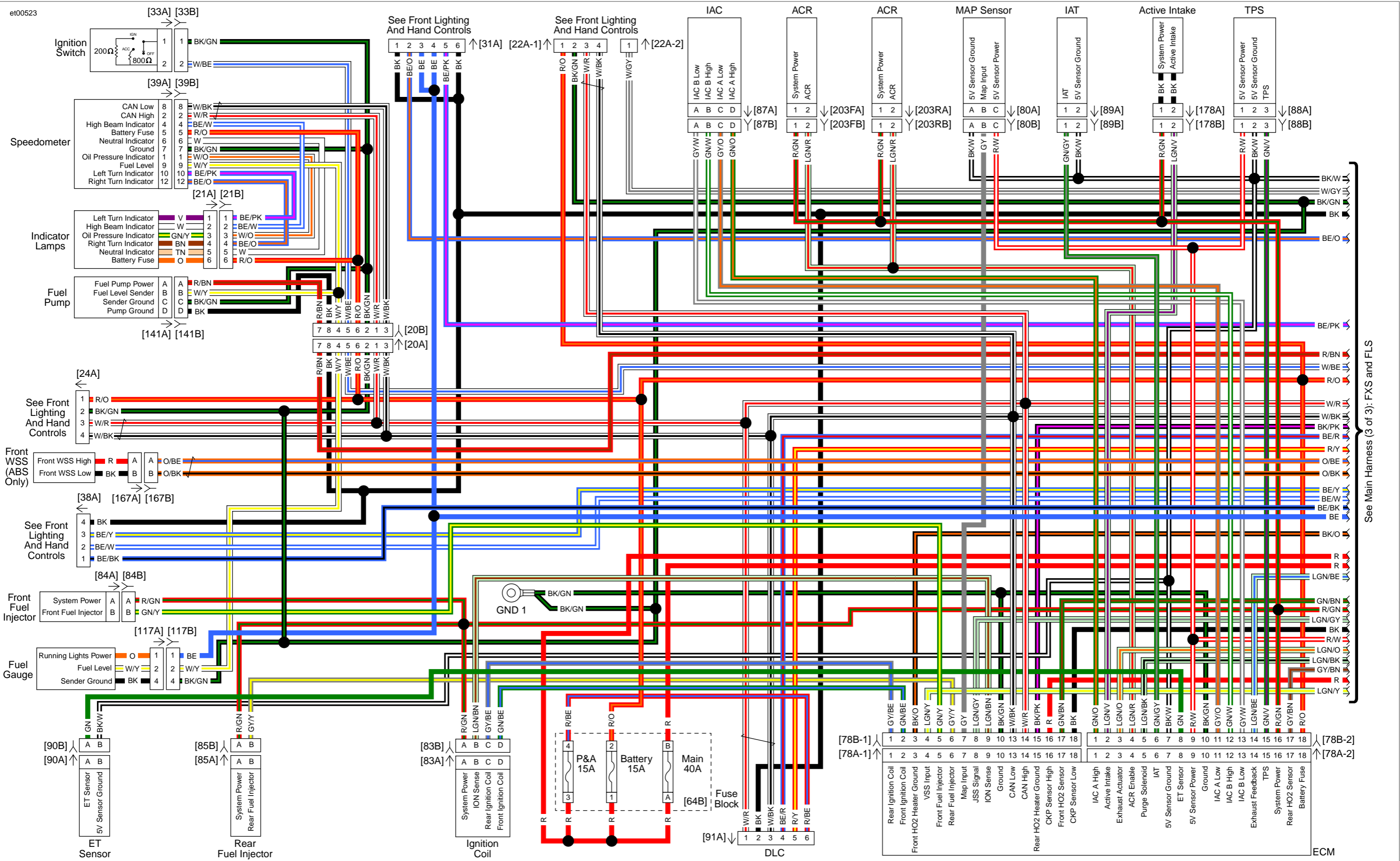

Figure B-14. Main Harness 2 of 3: 2013 Softail (FLS)

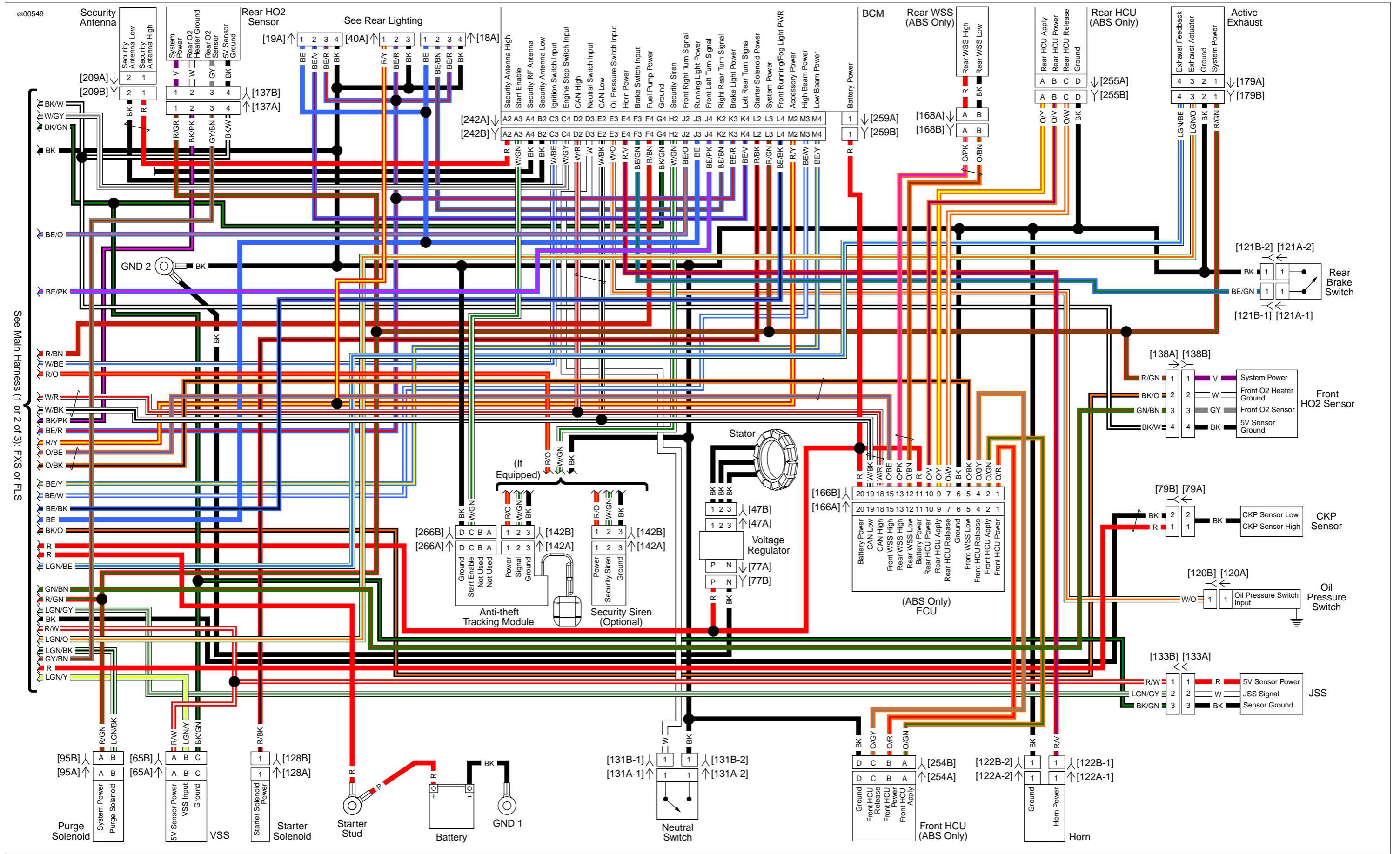

Figure B-15. Main Harness 3 of 3: 2013 Softail (FXS and FLS)

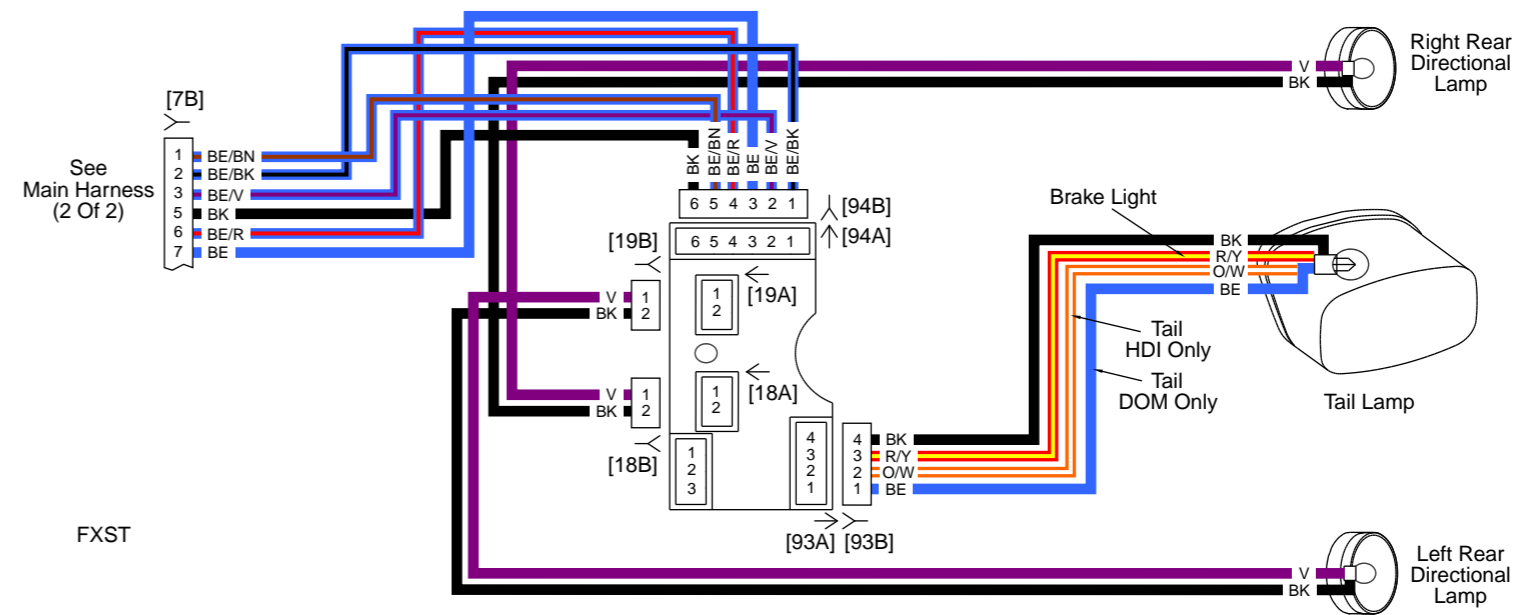
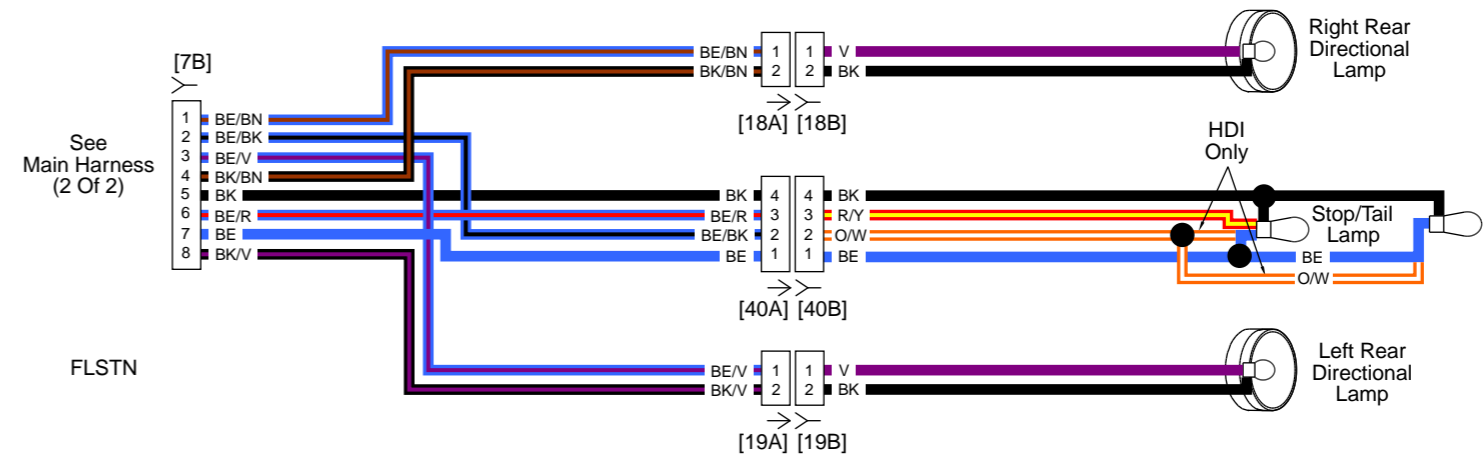
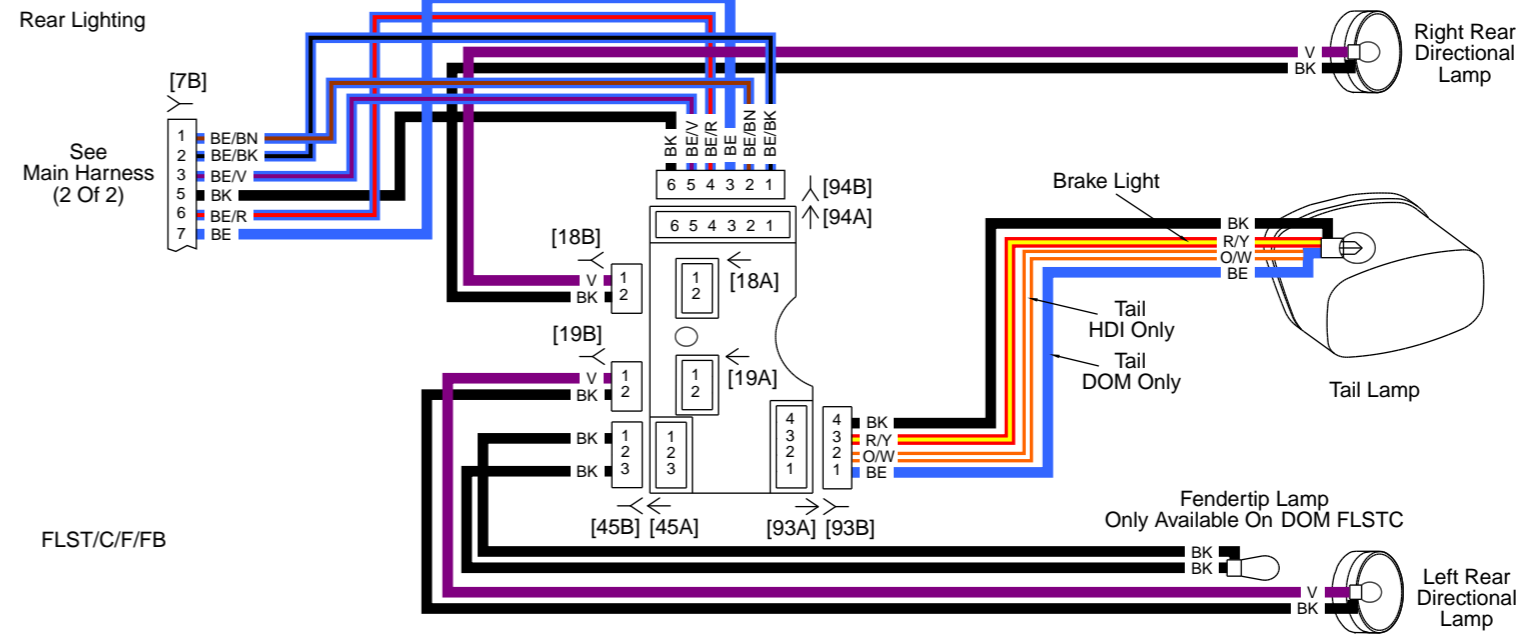
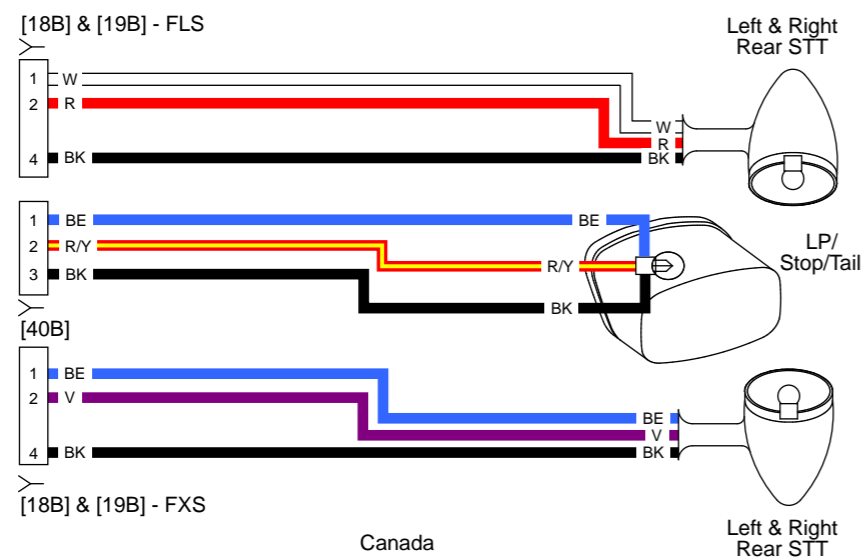
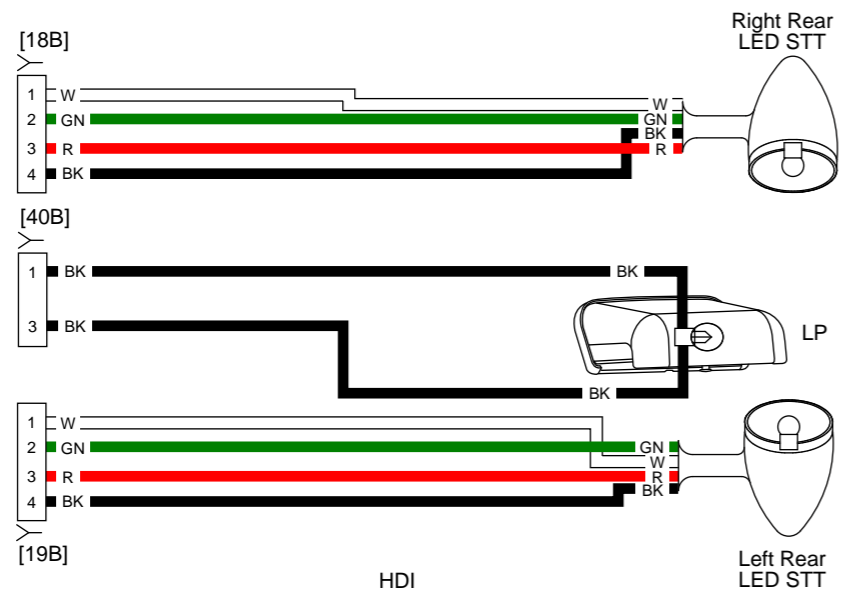
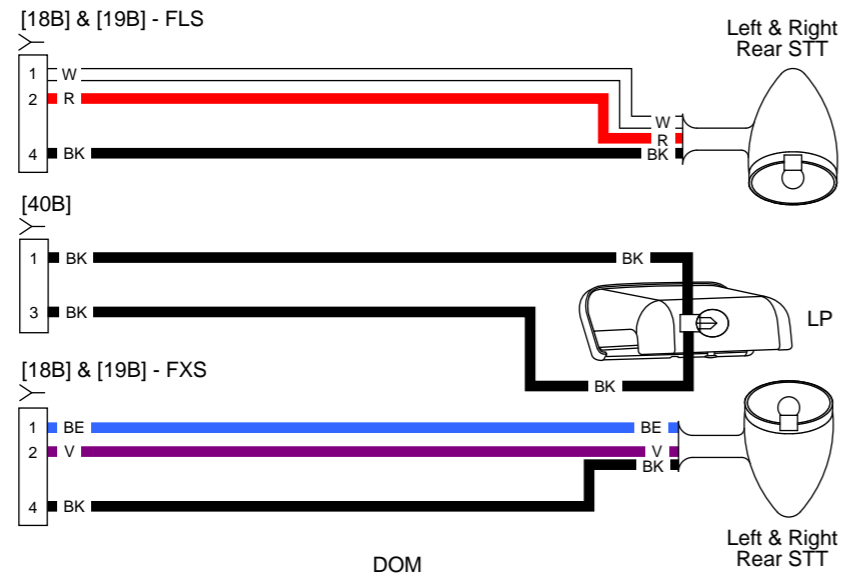

Figure B-16. Rear Lighting: 2013 Softail