



REDUCER SERVICE MANUAL
VERDAMPER REVISIE HANDLEIDING
VERDAMPFER REVISION ANLEITUNG

REDUCER SERVICE

Tools and products:

- Reducer replacement kit **180/10020**
- Reducer replacement kit **180/10025H**
- Allan key 4 mm
- Thread cutting device M10x1
- Ring spanner size 8 mm / 16 mm / 17 mm
- Torque spanner (0 -10 Nm) with socket 14 mm / 8 mm
- 14 mm socket with ratchet
- Special 19 mm socket (part nr. 099/9980) with ratchet
- Screwdriver (flat head)
- Hammer
- Air gun
- Brake cleaner / carburettor cleaner

Reducer parts not sold separately

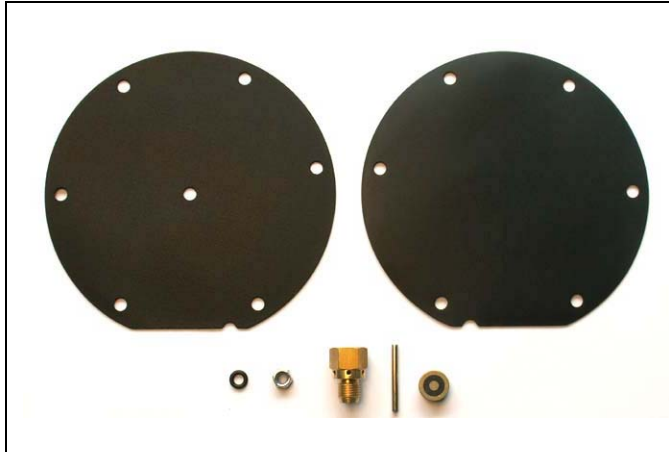

Reducer replacement kit 180/10020 :

- Gas-side diaphragm(4)
- Water-side diaphragm(5)
- Pressure relief valve O-ring(29)
- Locking nut M5(11)
- Jet(15)
- Locating pin(14)
- 3 pipes with 6 O-rings
- Valve seat(16)



Loosen the six Allen screws(18).
NOT the “Tensilock-nuts”(33),
 otherwise they will loose their locking
 function.



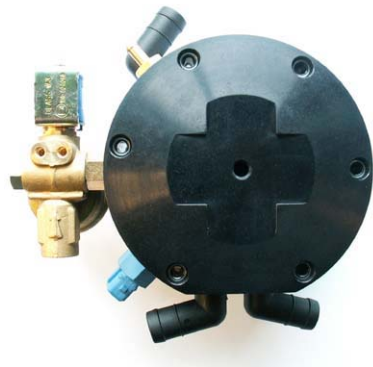

Remove the six Allan screws⁽¹⁸⁾.

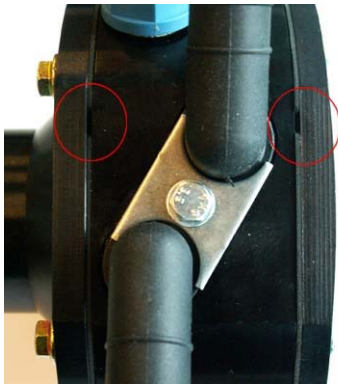

Use the recess in the diaphragms to separate the covers from the main body⁽¹⁾.

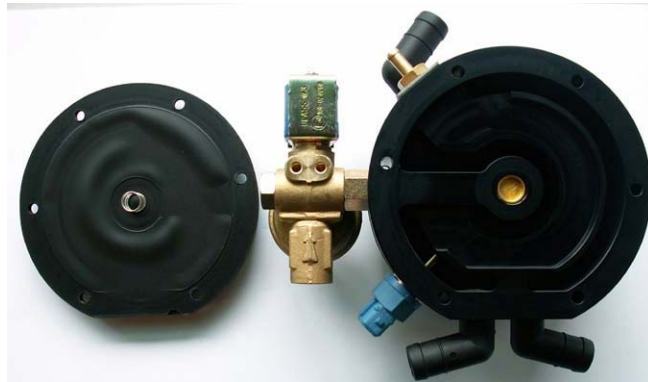

Remove the rear cover⁽²⁾.

The valve spring⁽¹⁷⁾ will be used again.

Remove the water-side diaphragm⁽⁵⁾ from the rear cover⁽²⁾.

The water-side diaphragm⁽⁵⁾ will be replaced.

Replace all the plastic pipes with o-rings.



Remove the valve seat⁽¹⁶⁾ and the locating pin⁽¹⁴⁾.



The valve seat⁽¹⁶⁾ and the locating pin⁽¹⁴⁾ will be replaced.



Remove the front cover⁽³⁾.

The complete adjusting disc⁽⁷⁾ and conical spring⁽¹⁰⁾ will be used again.



Replace the gas-side diaphragm.

The diaphragm bolt and disc will be used again.

Mount the disc⁽¹²⁾ with the 'sharp'-side facing the conical spring⁽¹⁰⁾.

Tighten the diaphragm bolt⁽¹³⁾ and disc⁽¹²⁾ with a new locking nut⁽¹¹⁾.
Torque setting : 2,5 Nm.



New diaphragm ready to install.

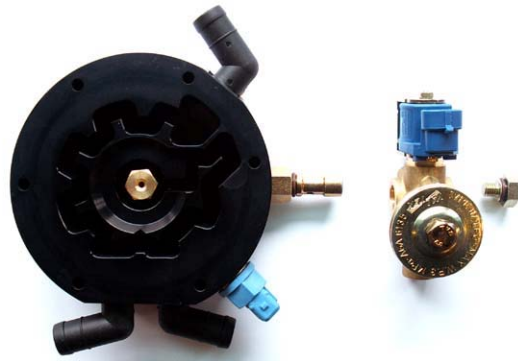

Remove the lock-off valve⁽³¹⁾ for cleaning the gas inlet channel.



Remove the jet⁽¹⁵⁾ from the main body⁽¹⁾.

Clean the main body thoroughly.



Remove the pressure relief device.



Replace the o-ring⁽²⁹⁾ from the pressure relief valve⁽²⁴⁾ and replace it with a new o-ring⁽²⁹⁾.



Clean the threaded hole with a thread cutting device (M10x1).

Clean the threaded hole and the main body thoroughly.

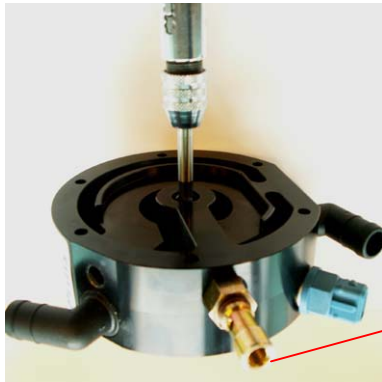

Clean the threaded hole with a thread cutting device (M10x1).

Clean the threaded hole and the main body thoroughly.

Clean the gas inlet with an air gun.
(When the valve pin is removed,
clean the M10x1 threaded hole).



When the main body⁽¹⁾ is completely free from pollution :

- Mount the new jet⁽¹⁵⁾ with a locking compound threebond 1305 or equal
Torque setting : 4 Nm
- Mount the pressure relief device.
Mount the nipple⁽²²⁾ with a locking compound threebond 1305 or equal.
Torque setting : 2,5 Nm



Replace the water-side diaphragm ⁽⁵⁾



Install the new valve seat⁽¹⁶⁾ with the rubber compound facing the jet⁽¹⁵⁾.
Install the spring⁽¹⁷⁾ on the new valve seat⁽¹⁶⁾.



Install the new water-side diaphragm⁽⁵⁾ on the back of the main body⁽¹⁾.
Make sure the valve spring⁽¹⁷⁾ is in position on the valve seat⁽¹⁶⁾.



Place the rear cover on the diaphragm and insert the six Allan screws.



Flip the reducer 180 degrees.
Use one hand on the rear cover to keep the screws in place.



Insert the new locating pin⁽¹⁴⁾ into the jet ⁽¹⁵⁾.
To check if the valve seat⁽¹⁶⁾ is installed properly, press the locating pin. The valve seat and location pin will be pushed back in start position.

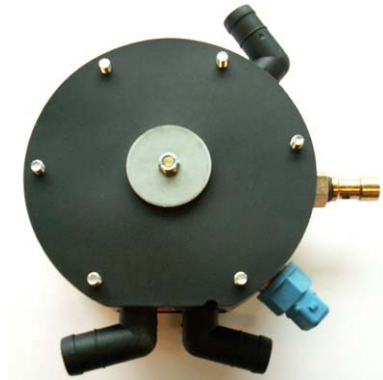

Install the new gas-side diaphragm on the main body.

 A black circular front cover with four mounting holes around its perimeter. Below it are a small metal pressure adjusting disc and a conical spring.	<ul style="list-style-type: none">- Front cover⁽³⁾- Pressure adjusting disc⁽⁷⁾- Conical spring⁽¹⁰⁾
 The black circular front cover with the pressure adjusting disc and conical spring installed in its center.	<p>Install the disc and spring into the front cover.</p> <p>Use the drive-in screw ⁽⁸⁾ for positioning the disc ⁽⁷⁾ in the cover.</p> <p>Without the drive-in screw, the pressure can not be adjusted.</p>



Install the front cover on the main body.

Tighten the Allen screws and NOT the “Tensilock-nuts”, otherwise they will loose their locking function.

Torque setting : 8 Nm.

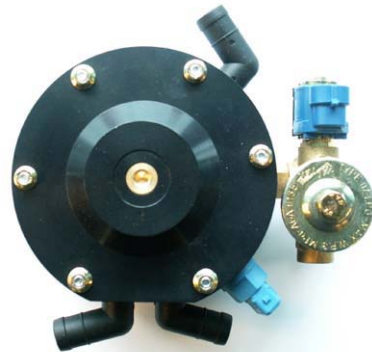

Test the reducer for proper functioning according the test procedure.

H-reducer : Reducer replacement kit 180/10025H

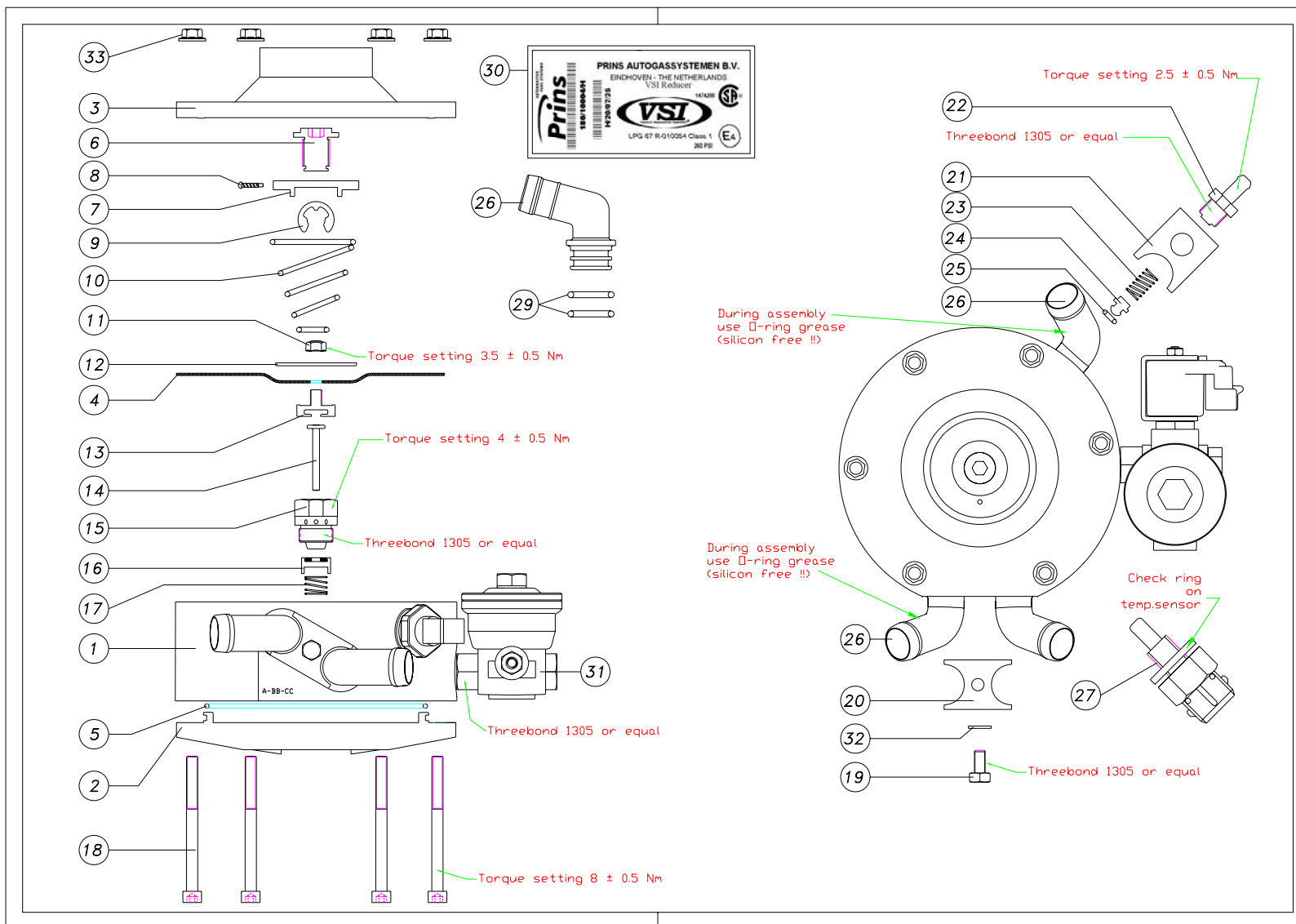

How to Calibrate the test procedure

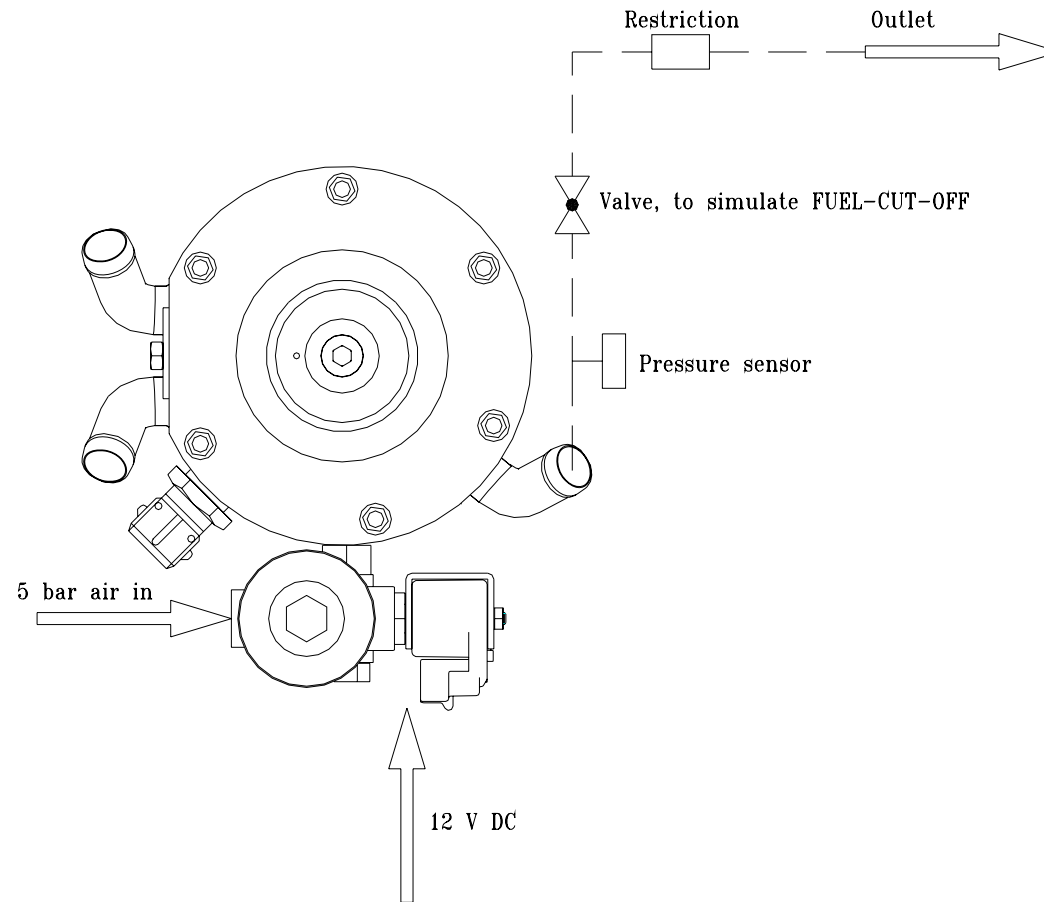

First steps before calibrating the test

- 1) Connect to the inlet air with a pressure of 5 bar abs.

- 2) Connect to the outlet a 16 mm hose with a pressure sensor, a manually operated valve and a restriction (1.0-2.0 mm orifice, depending of the restrictions of the INLET).
- 3) If necessary connect a silencer on the outlet to reduce the noise.
- 4) Connect 12 Volts to the coil.

Calibrating the test:

Use a new reducer to calibrate the restriction on the outlet

- 1) The outlet pressure should be 2.1-2.2 bar (factory default)
- 2) When air is flowing through the reducer, monitor the outlet pressure value and close the valve on the outlet.
- 3) The pressure may increase maximal 0.15 bar.
- 4) If the pressure increases more than 0.15 bar decrease the restriction of the outlet.

Procedure for testing the reducer

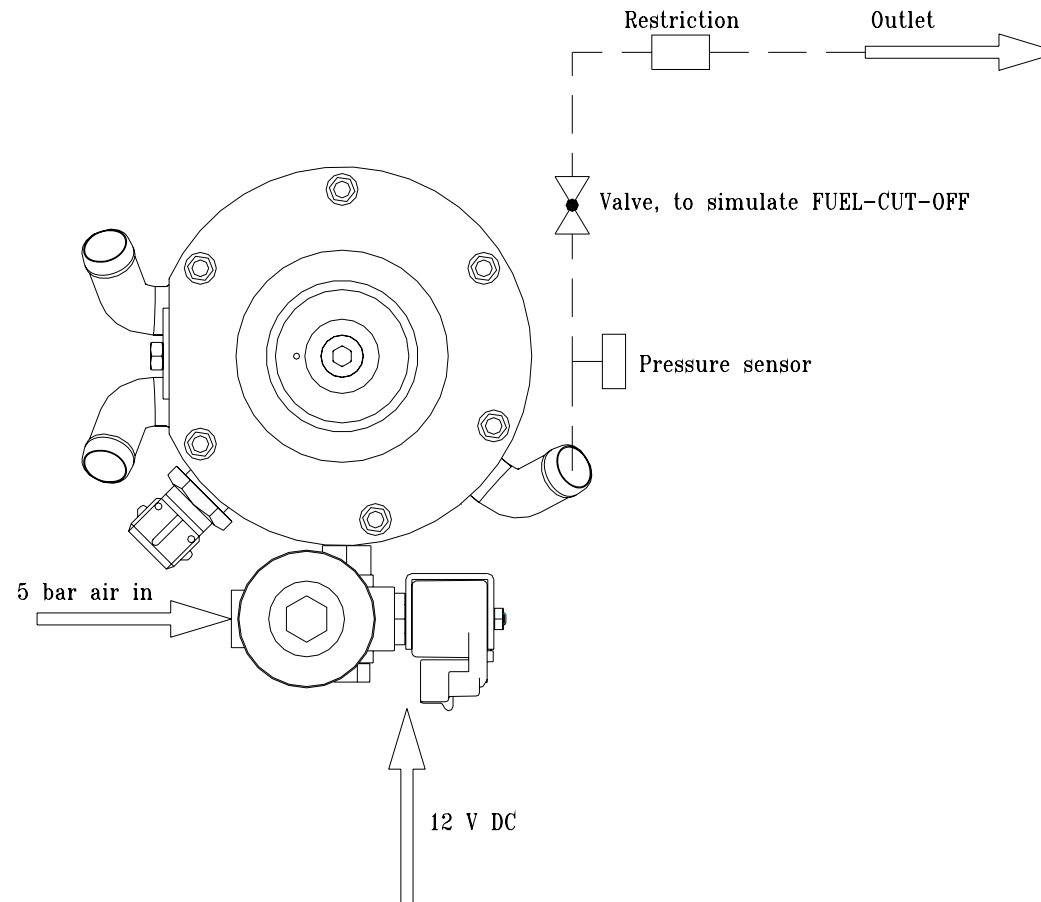

Testing a reducer

1. Connect to the inlet air with a pressure of 5 bar abs.

2. Connect to the outlet a 16 mm hose with a pressure sensor, a manually operated valve and a restriction
3. Connect 12 Volts to the coil.
4. Set the reducer to its maximum pressure (rotating adjusting bolt counter clockwise)
5. Pressure should be greater than 2.6 bar (abs).
6. When air is flowing through the reducer, monitor the outlet pressure value and close the valve on the outlet.
7. The pressure may increase maximal 0.15 bar, if the pressure keeps on rising, the reducer is leaking at the first stage valve (reject the reducer).
8. Set the reducer to its minimum pressure (rotating adjusting bolt clockwise)
9. Pressure should be less than 1.6 bar (abs).
10. Set the reducer to 2.2 bar (abs) (factory default).