

SPECIFICATIONS

DIAMETER:	15" (0.59 mm)
SENSITIVITY (2.83 V @ 1 m):	94 dB
POWER HANDLING:	600 W _{RMS}
FREQUENCY RESPONSE:	20 ~ 300 Hz
NOMINAL IMPEDANCE:	4 OHMS
VOICE-COIL DIAMETER:	4.0" (102.00 mm)

DIMENSIONS:

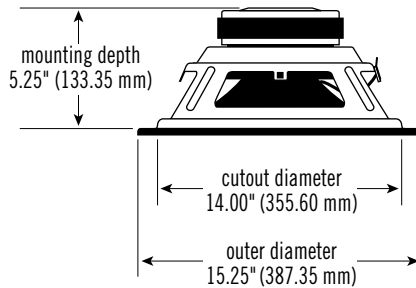

THIELE-SMALL PARAMETERS

VOICE COIL DC RESISTANCE:	R_{EVC} (OHMS) 2.50
VOICE COIL INDUCTANCE @ 1 kHz:	L_{EVC} (MH) 0.98
DRIVER RADIATING AREA:	S_D (IN ²) 135.34
	S_D (CM ²) 877.00
MOTOR FORCE FACTOR:	BL (TM) 13.49
COMPLIANCE VOLUME:	V_{AS} (FT ³) 8.01
	V_{AS} (LITERS) 188.95
SUSPENSION COMPLIANCE:	C_{MS} (μM/N) 173.00
MOVING MASS, AIR LOAD:	M_{MS} (GRAMS) 119.52
MOVING MASS, DIAPHRAGM:	M_{MD} (GRAMS) 104.59
FREE-AIR RESONANCE:	F_S (Hz) 35.00
MECHANICAL Q:	Q_{MS} 5.80
ELECTRICAL Q:	Q_{ES} 0.36
TOTAL Q:	Q_{TS} 0.34
MAGNETIC-GAP HEIGHT:	H_{AG} (IN) 0.32
	H_{AG} (MM) 8.13
VOICE-COIL HEIGHT:	H_{VC} (IN) 0.75
	H_{VC} (MM) 19.05
MAXIMUM EXCURSION:	X_{MAX} (IN) 0.22
	X_{MAX} (MM) 5.46

IMPEDANCE CURVE

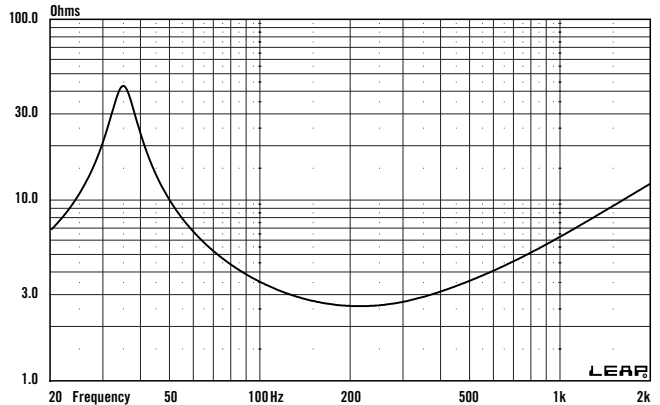

INFINITE BAFFLE FREQUENCY RESPONSE @ 2.83 V

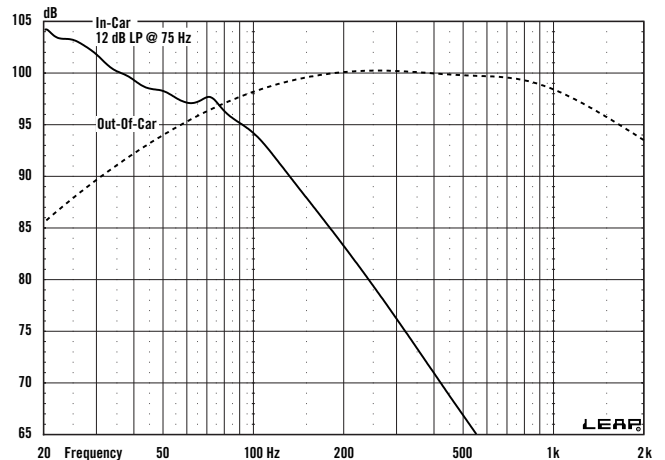

INFINITE BAFFLE EXCURSION/GROUP DELAY @ 150 W

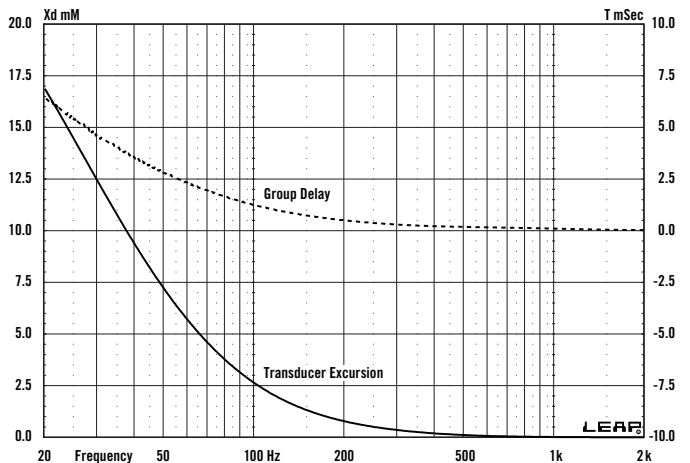

SEALED BOX VOLUME

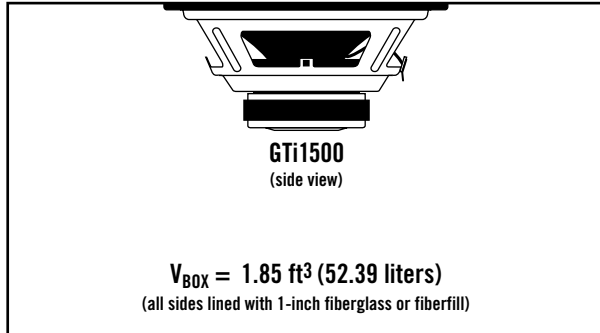

VENTED BOX VOLUME

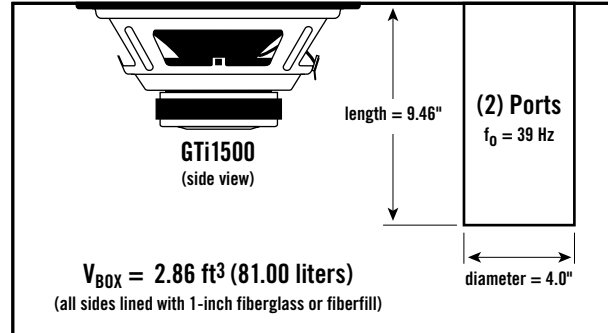

SEALED FREQUENCY RESPONSE @ 2.83 V

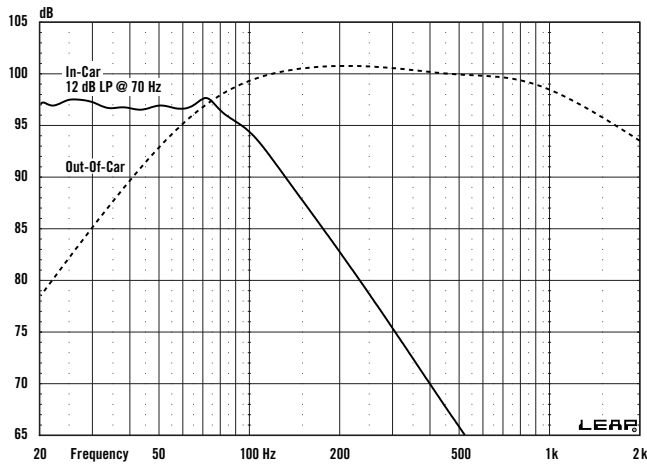

VENTED FREQUENCY RESPONSE @ 2.83 V

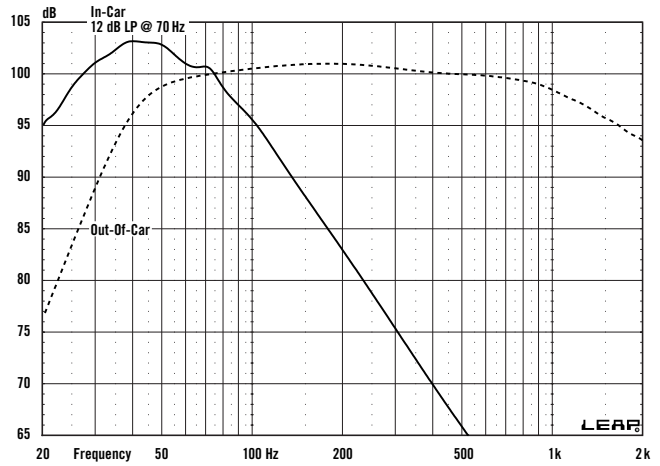

SEALED EXCURSION/GROUP DELAY @ 500 W

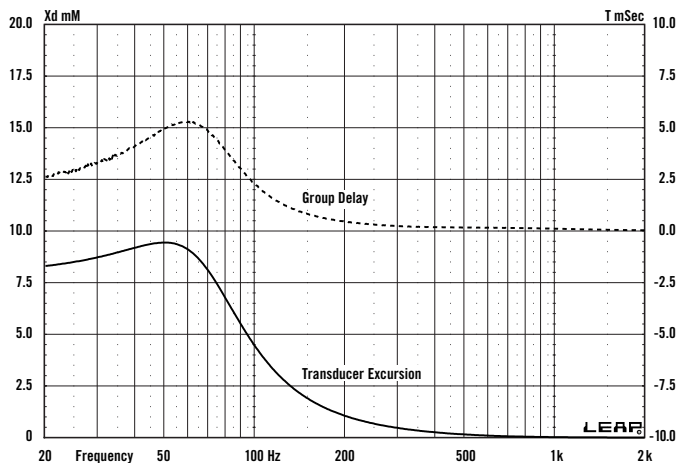

VENTED EXCURSION/GROUP DELAY @ 600 W

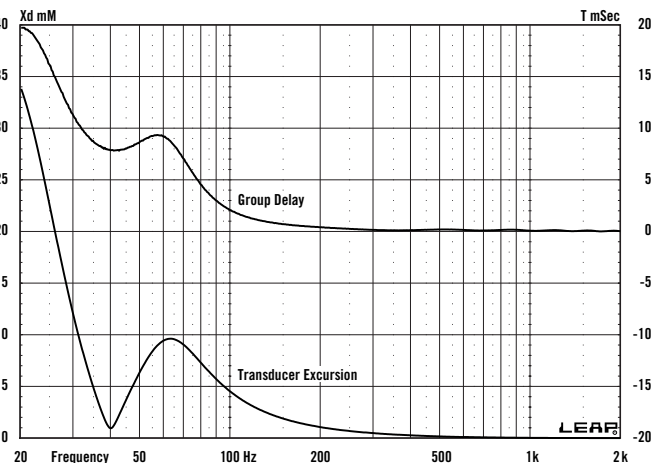

SEALED BANDPASS BOX VOLUME

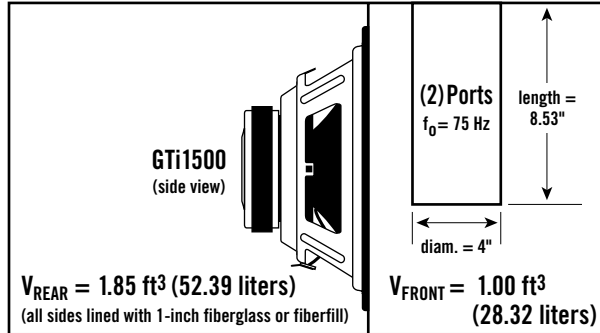

SEALED BANDPASS FREQUENCY RESPONSE @ 2.83 V

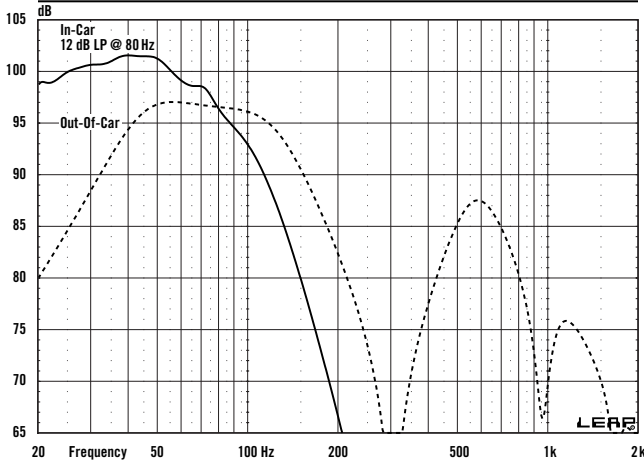

SEALED BANDPASS EXCURSION/GROUP DELAY @ 500 W

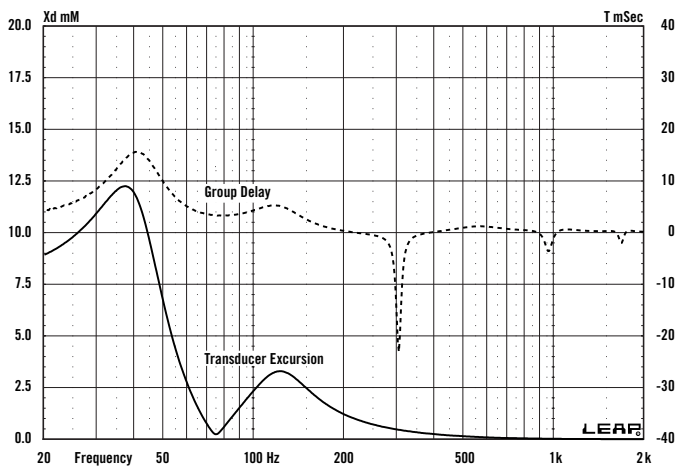

NOTES
